

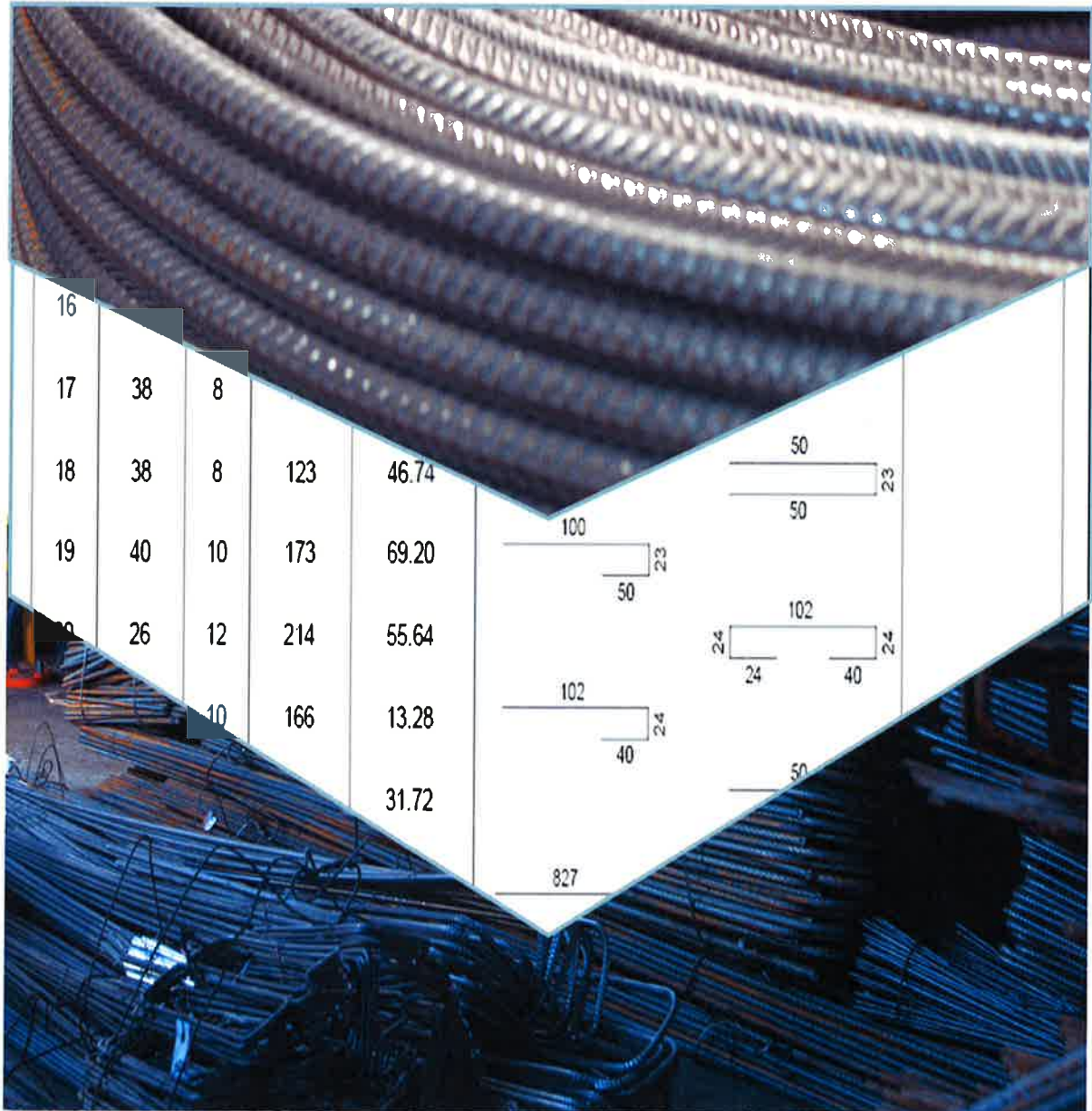

SSHV | ASCA

Schweizerischer Stahl- und Haustechnikhandelsverband SSHV
Association Suisse du Commerce de l'Acier et de la Technique du Bâtiment ASCA
Associazione Svizzera del Commercio dell'Acciaio e dell'Impiantistica ASCA

Liste des figures et directives pour le façonnage des fers à béton 2014



Directives et utilisation selon norme SIA

1. Les figures sont groupées en fonction du nombre de pliage. (par ex. numéro 331 = 3 pliages)



2. Dans le cadre des groupes, les figures sont classées par degré de façonnage. Les degrés de façonnage sont: degré de façonnage 1, degré de façonnage 2, degré de façonnage S.

3. Les figures qui ne sont pas représentées, tout comme les figures de forme 3D seront facturées en régie.

4. Les façonnages avec un galet de pliage $d1$ doivent être spécifiés expressément sur la liste de fer. Ces figures seront facturées selon le degré de façonnage S ou en régie.

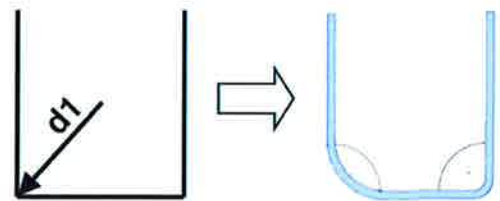

5. Les dimensions qui diffèrent de la tolérance SIA, doivent être mentionnées spécialement sur la liste de fer par un encadrement rectangulaire de la cote par l'ingénieur (par ex. 796). Ces figures seront facturées selon le degré de façonnage S ou en régie.

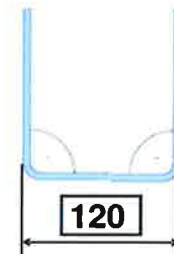

6. Si les étriers fermés ont une dimension de pliage inférieure à 21cm, ils seront facturés selon le degré de façonnage S.

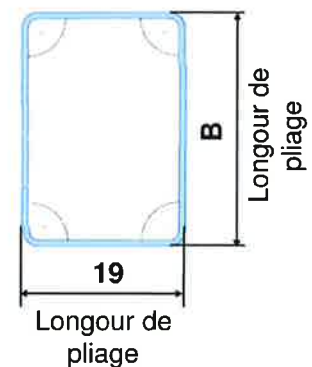

Directives et utilisation selon norme SIA

7. Les longueurs indiquées dans la liste de fer sont les dimensions extérieures en cm.

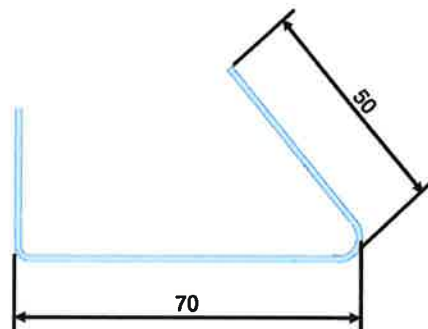

8. Le mandrin ou le galet de pliage (d) en mm est la dimension intérieure.

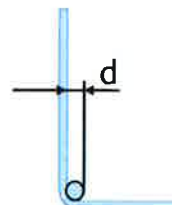

9. Le diamètre du fer à béton est toujours indiqué en mm

10. L'atelier de façonnage a absolument besoin d'une cote de longueur et d'un angle de pliage en degré (360°).

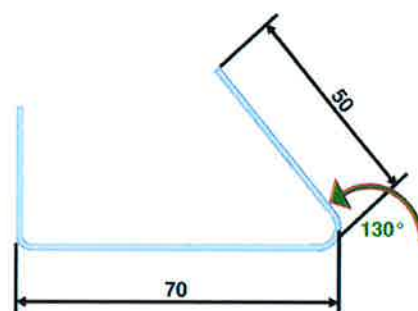

11. Les fers à béton coupés ou piliés jusqu'au diamètre 16mm sont pour raison technique produits et livrés en nombre pair et facturés ainsi.

12. Pour des raisons de technique de production, les longueurs de branches du début et du milieu ne peuvent pas être inférieures.

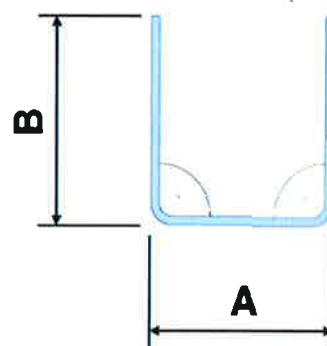

	Ø (mm)	A (cm)	B (cm)
d3	8	8	6
	10	10	7
	12	12	10
	14	14	12
	16	16	13
d2	18	22	17
	20	24	18
	22	32	25
	26	37	29
	30	42	33
	34	56	35
	40	64	44

13. Utiliser la grandeur de police 12 pour le dimensionnement.

14. Les sur-longueurs (> 14 m.) et sur-largeurs (> 2.5 m) seront facturées en régie.

**FIGURENLISTE
LISTE DES FIGURES
LISTA DELLE FIGURE**

Fix
Fixe
Fisso

1



Bearbeitungsgrad 1
Degré de façonnage 1
Grado di lavorazione 1

101



102



103



104

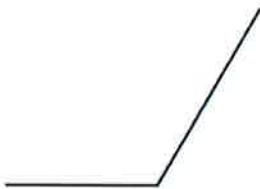

105

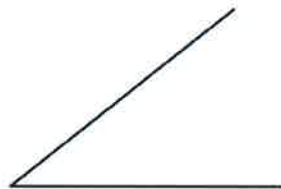

Bearbeitungsgrad S
Degré de façonnage S
Grado di lavorazione S

181

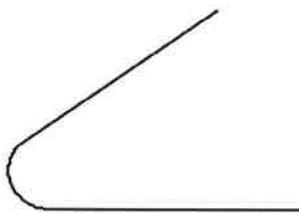

182



183



184



185

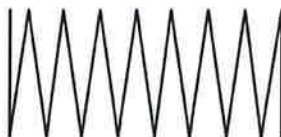

186

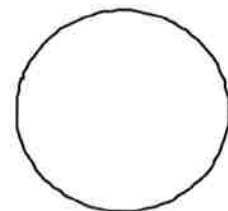

Bearbeitungsgrad 1
Degré de façonnage 1
Grado di lavorazione 1

201



202



203



205



206



207



208



209

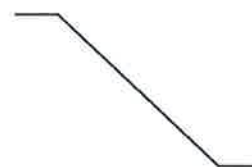

210



211



212



213

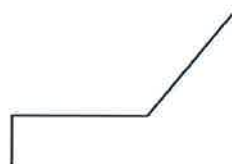

214

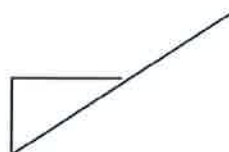

215



216

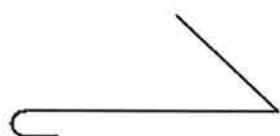

218



219

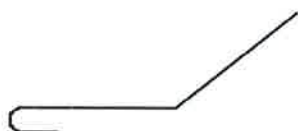

221



Bearbeitungsgrad 2
Degré de façonnage 2
Grado di lavorazione 2

231



232



233



Bearbeitungsgrad S
Degré de façonnage S
Grado di lavorazione S

281

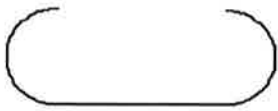

282 3D

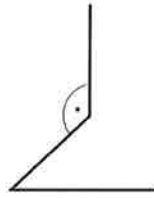

Bearbeitungsgrad 1
Degré de façonnage 1
Grado di lavorazione 1

301



302



303

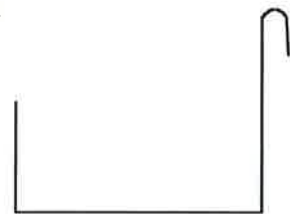

307

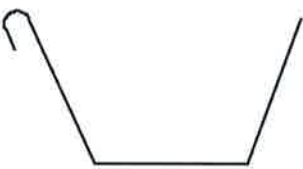

308

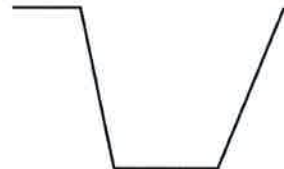

309

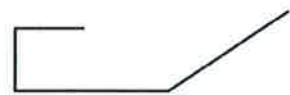

310

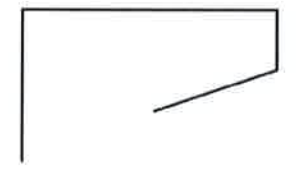

311

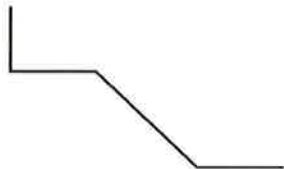

312



313



314

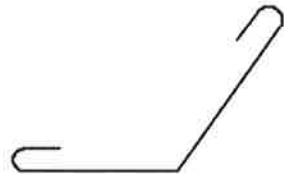

316



Bearbeitungsgrad 2
Degré de façonnage 2
Grado di lavorazione 2

331

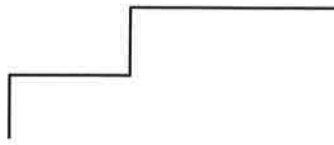

332

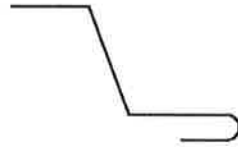

333

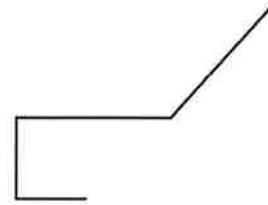

334



335



336

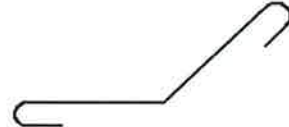

337



338

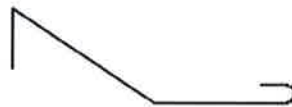

339

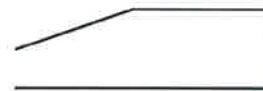

340



341

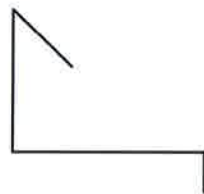

342

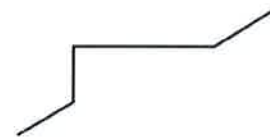

343



344

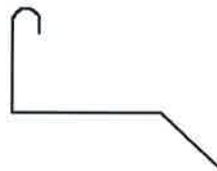

345

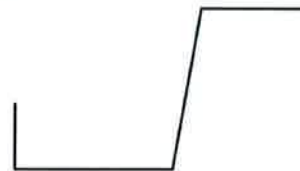

Bearbeitungsgrad S
Degré de façonnage S
Grado di lavorazione S

381



382

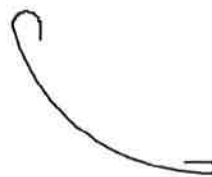

383

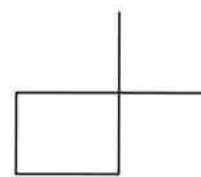

384



Bearbeitungsgrad 1
 Degré de façonnage 1
 Grado di lavorazione 1

401

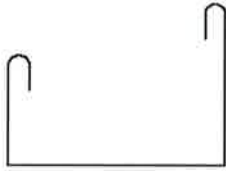

402

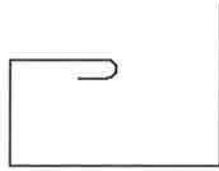

403

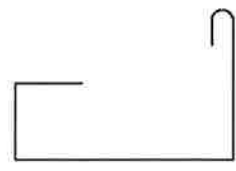

404

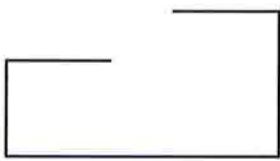

405

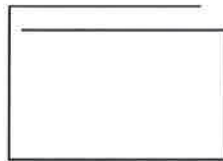

406

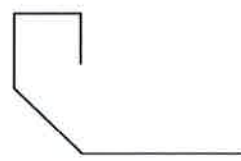

407

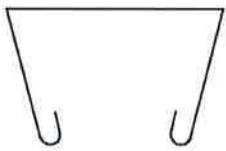

408



409

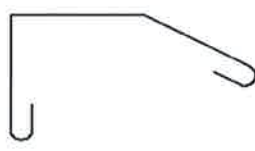

Bearbeitungsgrad 2
 Degré de façonnage 2
 Grado di lavorazione 2

431



432

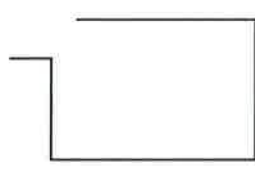

433

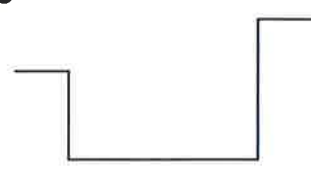

434



435

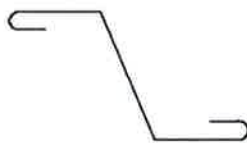

436

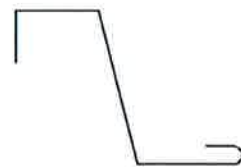

437

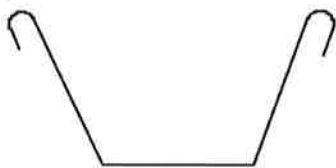

438

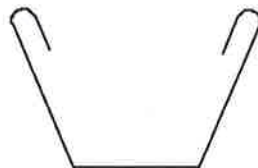

439

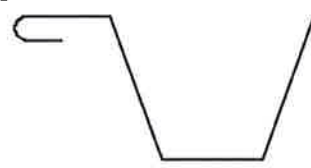

440

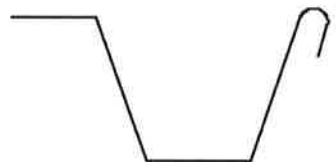

441

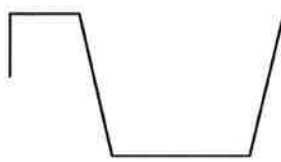

442

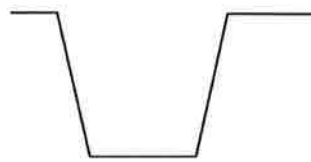

443

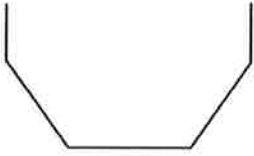

444

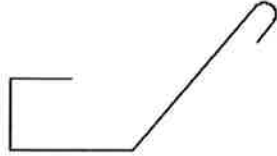

445

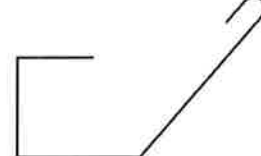

446

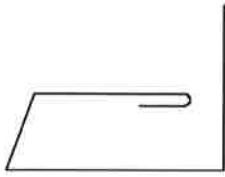

447

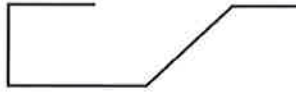

448

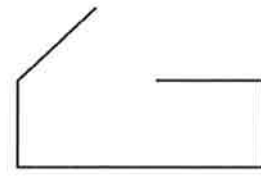

452

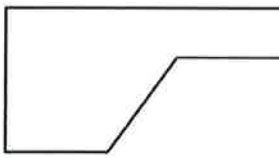

450



451

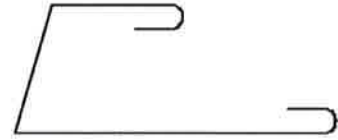

453

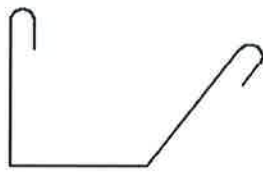

454



455

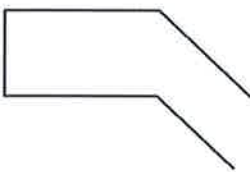

457

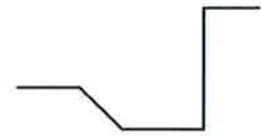

458

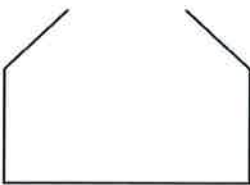

460

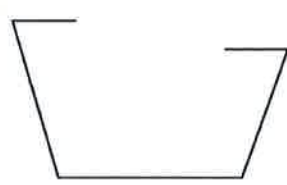

461



462



463

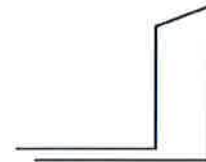

464



465

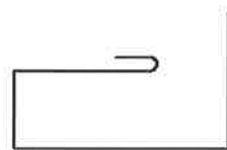

467

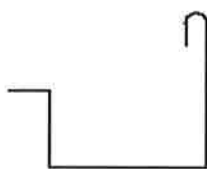

468

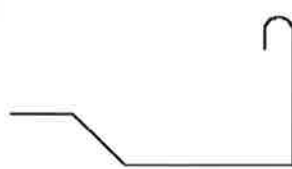

469

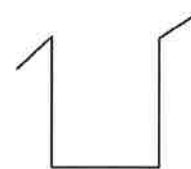

470

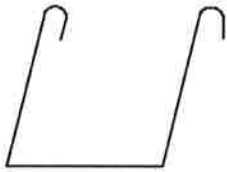

471

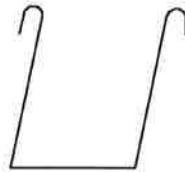

Bearbeitungsgrad S
Degré de façonnage S
Grado di lavorazione S

481 3D

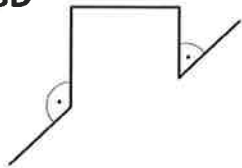

482 3D

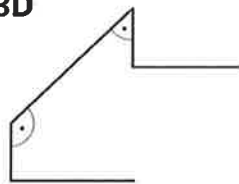

483 3D

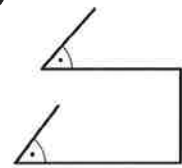

484

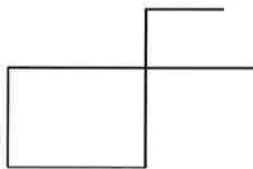

485

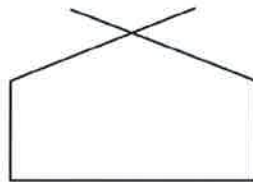

486



Bearbeitungsgrad 1
Degré de façonnage 1
Grado di lavorazione 1

501



Bearbeitungsgrad 2
Degré de façonnage 2
Grado di lavorazione 2

531

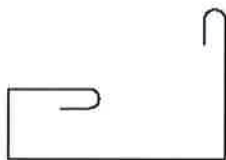

532

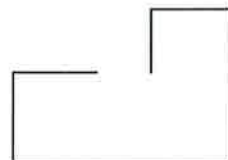

533

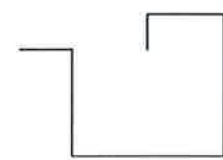

534



535



536

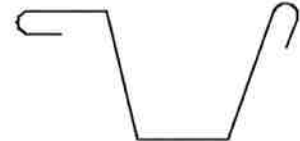

537

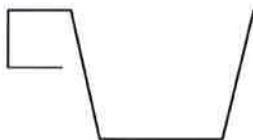

538

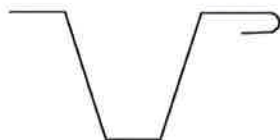

539

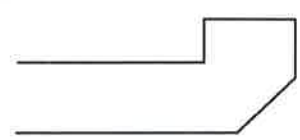

540

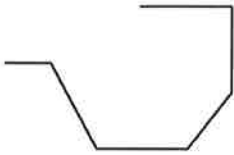

541

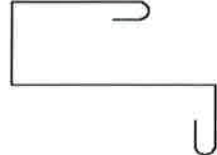

542



543

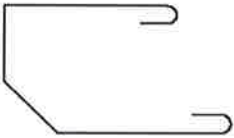

544



545



546

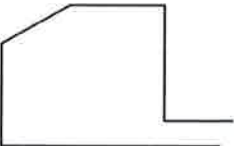

547

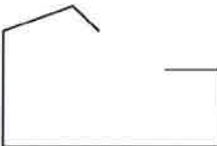

548



549

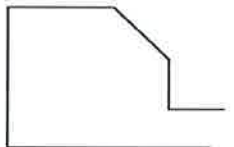

550

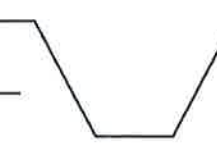

551



552

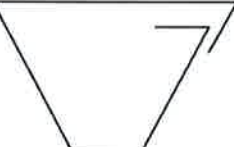

553



554

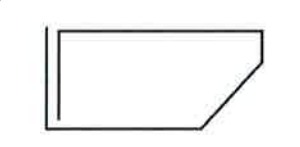

555



556

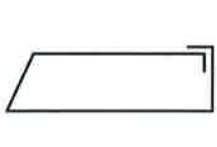

557

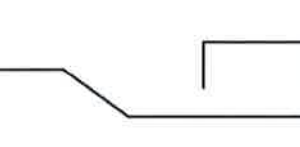

558

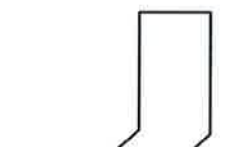

559



560



561



562



563



564



Bearbeitungsgrad S
Degré de façonnage S
Grado di lavorazione S

581

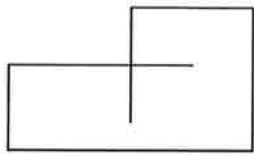

582

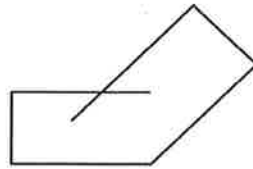

583

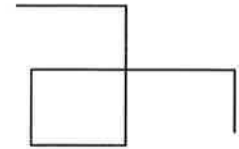

584

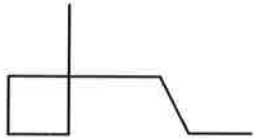

585

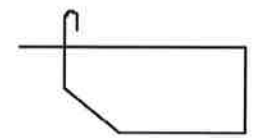

Bearbeitungsgrad S
Degré de façonnage S
Grado di lavorazione S

631

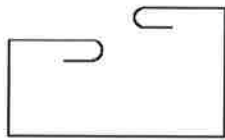

632

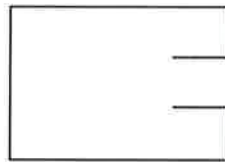

633



634

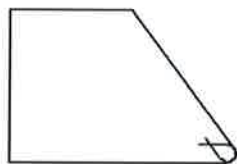

635

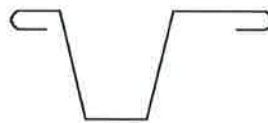

636

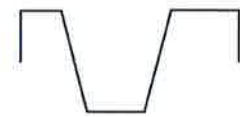

637



638

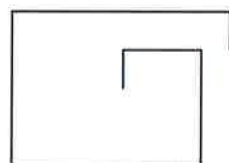

639



640



641

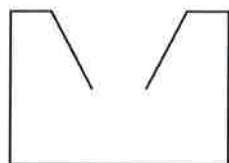

642

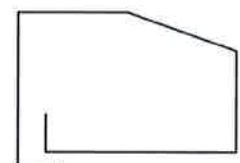

643

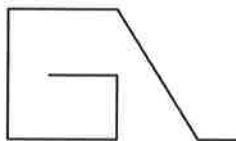

644



646

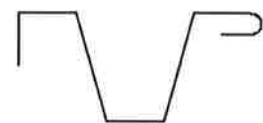

647

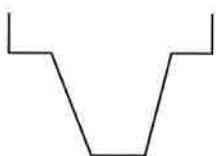

648

